

Ricoh Mirai

AKA Olympus AZ-4

This camera manual library is for reference and historical purposes, all rights reserved.

This page is copyright by mike@butkus.org, M. Butkus, NJ.

This page may not be sold or distributed without the expressed permission of the producer

On-line camera manual library

This is the full text and images from the manual.

If you find this manual useful, how about a donation of \$3 to:

M. Butkus, 29 Lake Ave., High Bridge, NJ 08829

This will help me to continue to host this site, buy new manuals, and pay their shipping costs.

It'll make you feel better, won't it?

If you use Pay Pal, use the link below. Use the above address for a check, M.O. or cash.



www.PayPal.me/butkus

[Click here for PDF version - better printing](#)

[Back to my main Camera Manual page](#)



From Nicholas Jones

Olympus AZ-4 I have found the Ricoh Mirai and the Olympus AZ-4 identical except for the following:

The AZ-4 has no remote control socket

The AZ-4 uses 2xCR123 batteries, not one lithium and not 4xAAA

The AZ-4 does not have bulb mode; the bulb mode button instead allows double exposure

A few of the LCD symbols are different;

On the AZ-4 'AV' for centre weighted average mode is instead 'F.I.' for Fill In flash

A C is used instead of a symbol on the button for continuous shooting mode.

There is no AE lock button on the AZ-4

There is a button marked 'spot' on the AZ-4 where the fill in flash

button is on the Ricoh Mirai. I have yet to determine what it does. The shape of the camera body is different

(top is round as opposed to

having a bump in the middle)

CONTENTS

I. PREPARING TO SHOOT ...7

1. Inserting Battery ...8

2. Turning the camera ON ...10

3. Monitoring Battery Condition ...11

4. Loading the Film ...13

5. Setting the Film Speed ...17

6. Viewfinder Indicators ...18

7. LCD Data Panel ...21

8. How to Hold Your Camera (Using the Multi-Position Grip) ...24

II. BASIC STEPS ...27

1. Turning the Camera ON for Fully Automatic Operation ...28

2. Zooming the Lens ...28

3. Auto focusing ...30

4. Shooting ...31

5. Rewinding the Film ...32

LOCATING THE CONTROLS

When reading this manual, refer to "Locating the Controls"
(Fold out the front and back covers).

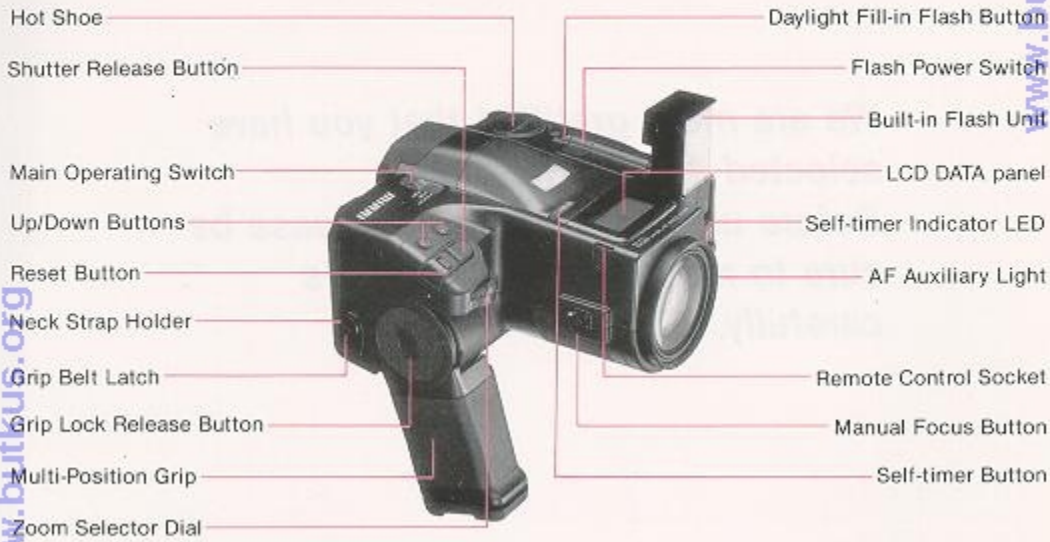

III. MAKING THE MOST OF YOUR CAMERA ...37

1. Auto focus Techniques ...38
2. Pre-Focus Shooting ...40
3. Manual (Power) Focus ...42
4. Macro Setting ...43
5. Continuous Shooting Mode ...46
6. Metering Modes ...49
7. Understanding Programmed AE ...53
8. Auto Program Shift ...53
9. Manual Program Shift ...54
10. AE Lock ...56
11. Exposure Compensation ...58
12. Bulb (long exposure) Photography ...61
13. Remote Control Socket ...64
14. Flash Photography ...65
15. Daylight Fill-In Flash ...67

- 16. Flash Photography with Speedlite SL-301M ...69
- 17. Using the Self-Timer ...71
- 18. Using the Self-Timer with Flash ...73
- 19. Reset Button ...74

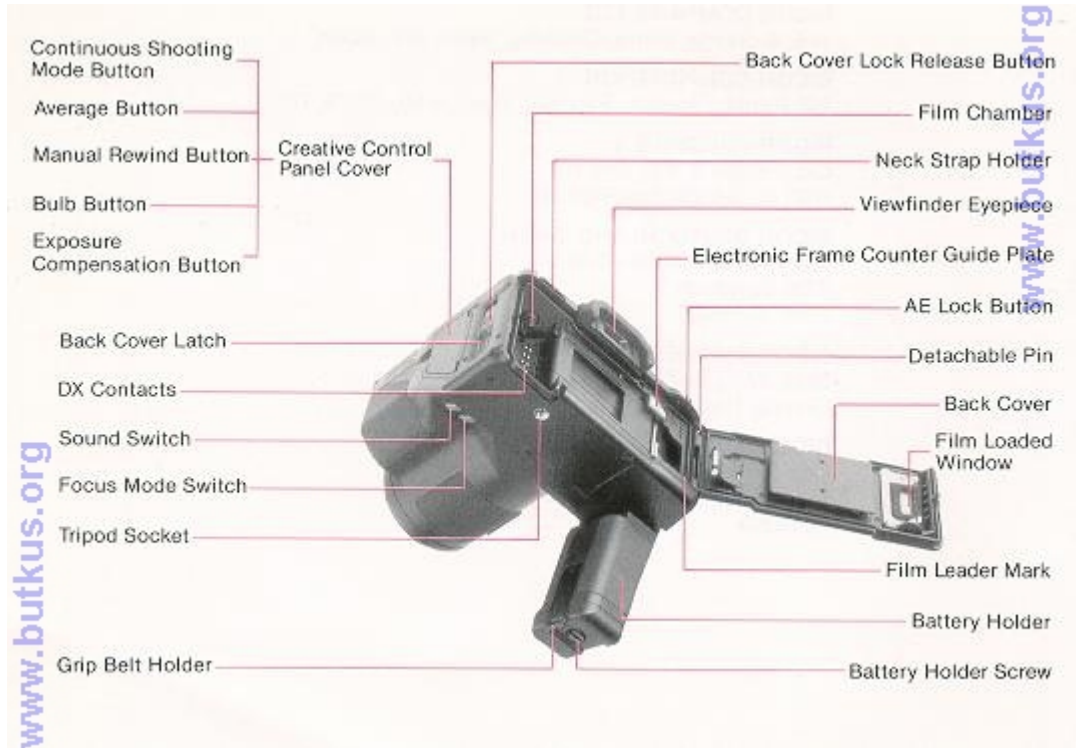

- IV. CARING FOR YOUR CAMERA ...75
- V. HELP! (Troubleshooting Guide)...77
- VI. ACCESSORIES ...81
- VII. APPENDIX (Charts, Diagrams) ...85
- VIII. MAJOR SPECIFICATIONS ...91

1. INSERTING BATTERY

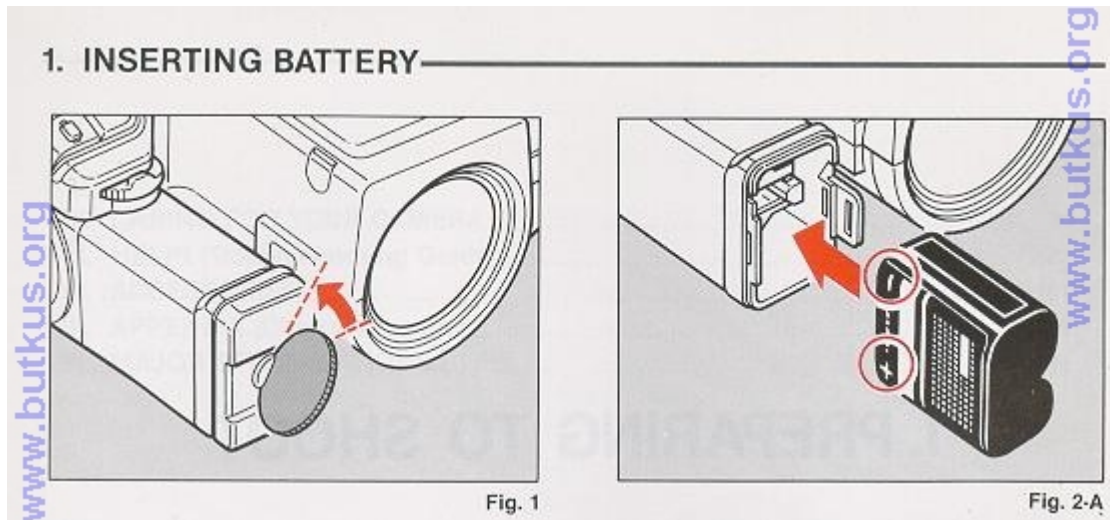

1. Remove the Battery Holder by turning the Battery Holder Screw counterclockwise with a coin. (Fig. 1)

2. Insert fresh a lithium battery or four AAA size batteries into the Battery Holder, first checking that the + and - on each battery are aligned according to the polarity diagram inside the Battery Holder. (Fig. 2 A, 2.B)

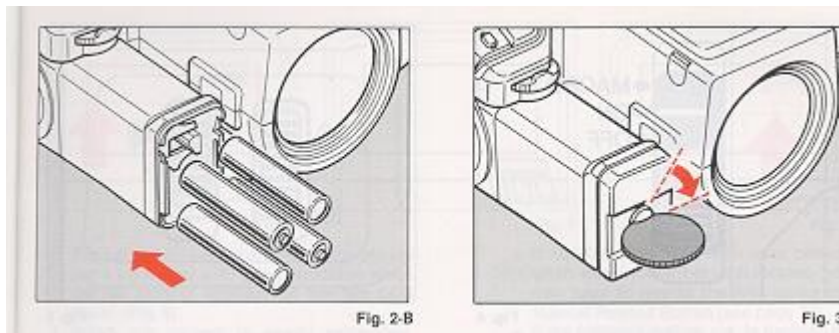

3. Resecure the Battery Holder to the Camera Grip by turning the Battery Holder Screw clockwise with a coin. (Fig. 3)

Battery Choices:

* Lithium battery (CR-P2 or equivalent) is recommended. Four AAA (AM-4) alkaline batteries can be used.

* Condition of battery (batteries) should be monitored frequently. See section "Monitoring Battery Condition" on page 11 for details

Care of Battery:

1. Before installing, be sure to wipe all moisture and skin oil off both battery contact surfaces in order to prevent future problems of corrosion and poor electrical contact.

* Dispose of used battery properly. Do not throw it into fire or expose to high temperature.

2. TURNING THE CAMERA ON

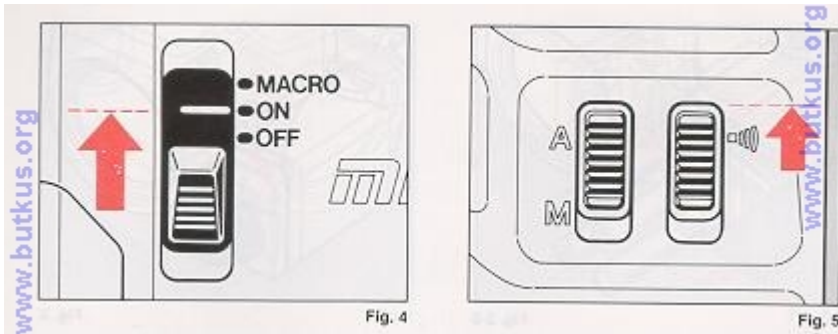

1. Slide the Main Operating Switch (Power On/Off and Macro) to ON. (Fig. 4)

* The camera is designed to shut off the main power supply automatically to save battery energy when the camera is not in use for about 15 sec. even if the Main Operating Switch is left ON. This will turn off the top LCD Panel and the Viewfinder but the information contained in camera memory will be retained. Lightly press the Shutter Release Button to turn on the power and update the LCD Panel. For maximum battery life, always turn the Main Operating Switch to the OFF position when the camera is stored.---

* If you set the Sound Switch on the bottom of the camera (Fig. 5) to the sound mark A), beep will be heard whenever proper auto focus is obtained, the self timer is used, etc. This confirms that your selection has been made.

3. MONITORING BATTERY CONDITION

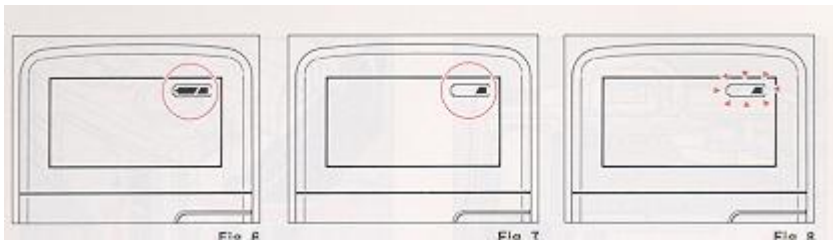

1. The battery (or set of batteries if you are using 4 AAA-size) is in good condition when the sac symbol appears on the top LCD Panel. (Fig. 6)

2. When the battery is nearly exhausted, the  symbol will be displayed on the top LCD Panel. (Fig. 7)

When the  symbol appears, it is recommended to replace the battery with a fresh one. If there is film in your camera, finish the roll as soon as possible and then replace the old battery with a fresh one. Fig. 8

* If non-DX-coded film is in your camera when the  symbol is displayed, you may have to rewind the film using the Manual Rewind Button (see page 33).

* If the battery's outline  is flashing do not use the flash unit until the battery is replaced. (Fig. 8)

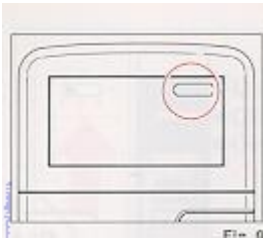

3. When the battery is virtually dead the "empty battery" symbol will appear in the LCD Panel.

Replace with a fresh battery. (Fig. 9) _

* If the "empty battery" symbol lights for about one minute, then disappears, the battery is only capable of retaining camera memory. Do not attempt to use other camera functions, and do not remove old battery until you are ready to replace it with fresh one. The memory of the camera will be retained for about 30 minutes without battery. If you replace with new battery within that 30 minutes, the display of all data in the camera memory will reappear in the LCD Panel.

* Cold temperatures may reduce any battery's efficiency. In freezing weather, only

the  symbol may show on the LCD Panel. If you are taking pictures in extremely cold weather, keep the battery warm and insert it just before shooting.

4. LOADING THE FILM

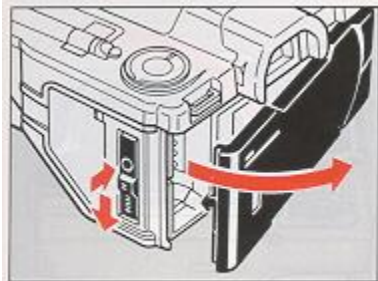

Fig. 10

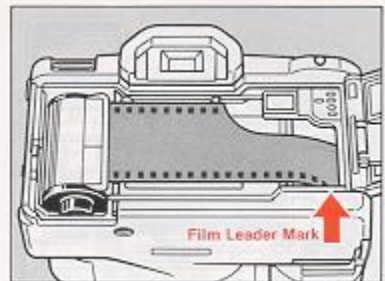

Fig. 11

Always avoid direct sunlight when loading the film. 1. Depress the Back Cover Lock Release Button and slide the Back Cover Latch down. (Fig. 10)

2. Load the Film Cassette into the Film Chamber and pull out enough film leader to extend just beyond the film leader mark, against the Take-up Spool. (Fig. 11)

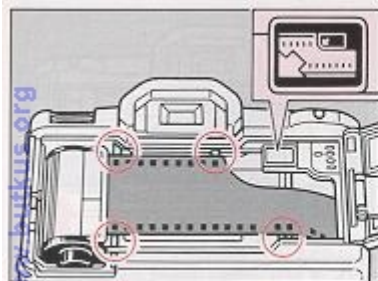

Fig. 12

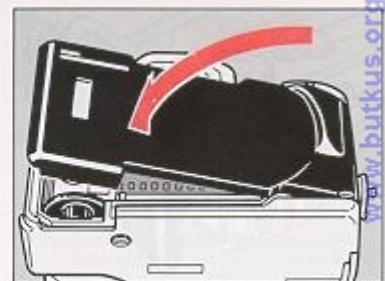

Fig. 13

3. Make sure that the film is within the Film Guides, and that the upper sprocket edge will pass under the Electronic Frame Counter Guide Plate. (Fig. 12)

4. Close the Back Cover, making sure that the Back Cover Latch snaps shut. (Fig. 13) The film will now automatically advance until number "1" appears on the top-deck LCD Panel. (Fig. 14)

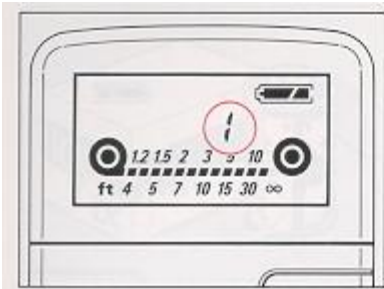

Fig. 14

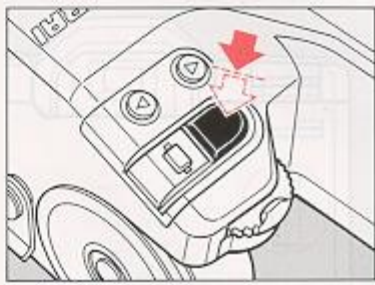

Fig. 15

Then, the LCD Panel will show the information. (Fig. 14)

* If the display shuts off, lightly press the Shutter Release Button halfway to reactivate the LCD. (Fig. 15)

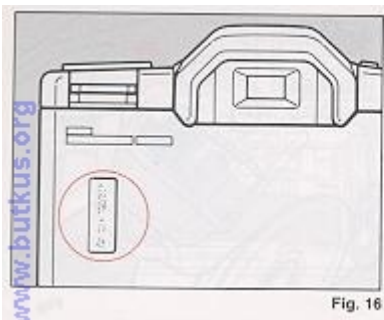

Fig. 16

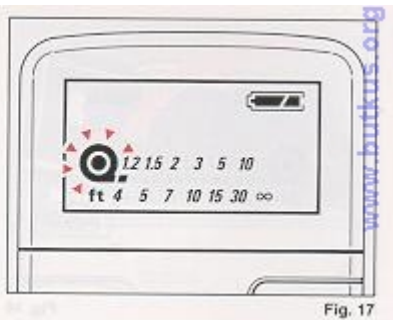

Fig. 17

* The Film Loaded Window on the back of the camera can be used to check whether there is film in the camera or not. (Fig. 16)

5. If the film has not advanced correctly or was not taken up onto the Film Take-up Spool, the Film Cassette Loaded symbol on the LCD Panel will blink for about 15 sec. (Fig. 17 and the shutter release will lock.)

Reload the film correctly by repeating steps 1-4 shown above.

Note: If Non-DX film is loaded in your camera, no warning will appear on the LCD and the shutter release does not lock.

5. SETTING THE FILM SPEED

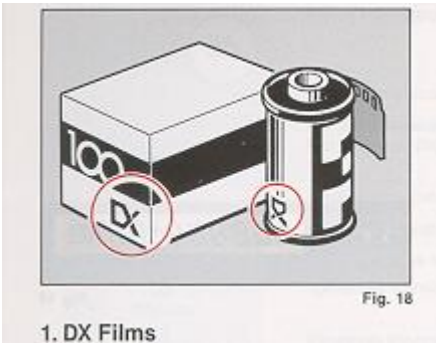

Fig. 18

1. DX Films

1. DX Films

DX-coded film cartridges are marked with black-and-silver patterns corresponding to the film speed and other information. Your camera reads this pattern and automatically sets itself for DX-coded film speeds ranging from ISO 25 to 5000. (Fig. 18)

2. Non DX Films

If Non-DX Film is used, your camera automatically sets itself to ISO 100. (Refer to the exposure compensation (pages 58) when you make manual adjustments while loading Non-DX film in your camera.)

6. VIEWFINDER INDICATORS

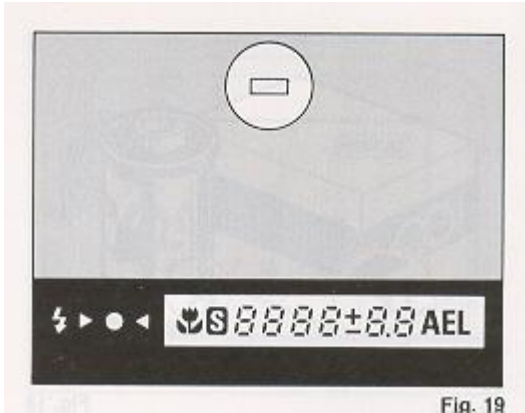
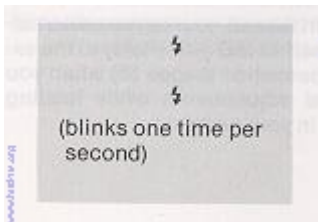









Fig. 19

1. Auto Focus Frame

When activated, the Auto-Focus System focuses automatically on any subject that appears within this small rectangle.



2. Viewfinder Display Panel

 (blinks four times per second)	: Out of flash range (Shutter will still fire)
 (blinks 2 times per second)	: Subject in focus
 	: Distance measurement cannot be made automatically; use manual focusing (see page 42); or if too close, shift to macro mode (see page 43).
 	: Manual focus shift direction indication (toward near) : Manual focus shift direction indication (toward infinity)
 (blinks)	: Macro Mode is set. : Too-close warning: Switch to Macro Mode.
 L 32-2000	: Exposure Program Shift indicator : Shutter Speed



	<p>: Overexposure warning</p> <p>: Underexposure warning</p>
	<p>: Hand Shaking warning with 35mm-70mm focal lengths blinks at 1/30 sec. or less.</p> <p>: Hand Shaking warning with 70mm-135mm focal lengths blinks at 1/60 sec. or less.</p>
	<p>: Exposure Compensation is set.</p>
	<p>: F-stop...</p>
	<p>Overexposure warning (Actual f-stop number varies with focal length.)</p> <p>Underexposure warning (Actual f-stop number varies with focal length.)</p>
	<p>AE Lock is set.</p>



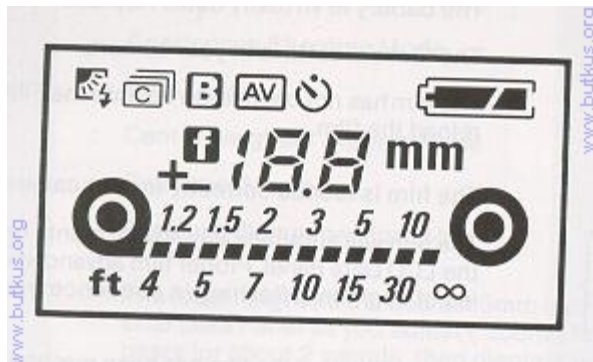

*** Viewfinder illumination**



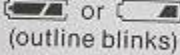

on automatically when the finder LCD is dark and difficult to see.

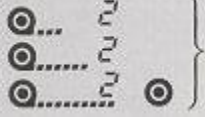
7. LCD DATA PANEL



	: The battery is in good condition.
	: The battery is nearly exhausted. If there is film in your camera, finish the roll as soon as possible and then replace the old battery with a new one.
 (outline blinks)	: The battery is not powerful enough to fire the flash unit. Do not use the flash unit....

	The battery is virtually dead. Replace with new battery.
 (blinks)	The film cassette is in your camera. The film has not been taken up onto the Film Take-up Spool. You must reload the film.
	The film is loaded correctly in your camera, you can make a shot.
	The film will automatically advance until next number "2" appears on the LCD Data Panel. Proper film advancement is indicated by the series of segments flashing in sequence from left to right.
	When the end of the film has been reached, the film will automatically rewind. The film rewind is indicated by the series of segments flashing in sequence from right to left, while the counter is displaying a countdown reading.
	When the film is fully rewound, the motor stops automatically and "E" appears in the LCD Data Panel. You can now open the Back Cover to unload the film....

	: Fill-in Flash Photography Mode
	: Continuous Shooting Mode
	: Bulb Mode
	: Center-weighted Average Mode
	: Self-timer Mode

+ or - (blinks after setting)	: Exposure Compensation Mode
35 mm - 135 mm	: The focal length (to the nearest 5mm increment) is indicated on the LCD Data Panel as you adjust ("zoom") the lens focal length. It appears for about 2 seconds, then displays the frame number.
1 - 36	: Number of exposures
12 1.5 12 1.5 2 3 5 10 ft 4 5 7 10 15 30 ∞	: The distance of your subject is indicated: 1.5m (4.9ft) : The distance of your subject is indicated: Infinity (00)
1.2	: Macro Mode

8. HOW TO HOLD YOUR CAMERA

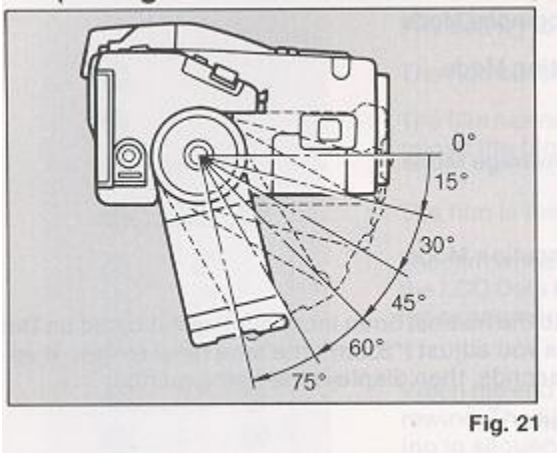

The Mirai's convenient Multi-Position Grip allows you to maneuver the camera easily and comfortably.

The Grip can be adjusted to 0°, 15°, 30°, 45°, 60° and 75° angles for maximum comfort when the index finger is on the Shutter Release Button. To adjust the Grip, press the Grip Lock Release Button while pushing the Grip down until it locks into the desired position. (Fig. 21)

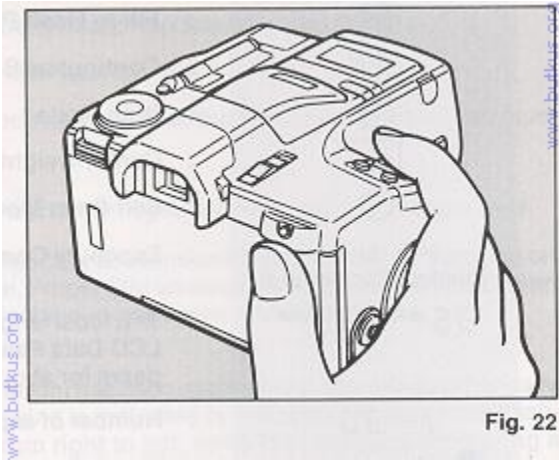

1. Lightly put your right-hand forefinger on the Shutter Release Button while holding the Camera Grip with other fingers. Your thumb should be positioned near the AE Lock Button on the back of the camera. (Fig. 22) _



2. Make sure your right arm is comfortable, but keep it as close to your body possible for maximum steadiness.

3. Use your left hand to steady the camera. (Fig. 23.A, 23.B)

4. Look through the Viewfinder to compose your picture.

* When holding taking flash pictures with your camera held vertically, always position it with the flash side up.

* It is important to practice holding the camera steady to avoid blurred or tilted pictures.

II. BASIC STEPS

1. TURNING THE CAMERA ON FOR FULLY AUTOMATIC OPERATION

When you slide the Mirai's Main Operating Switch to the ON position, the camera is ready for point-and-shoot operation. It automatically turns on the basic (or "default")

settings for all functions.

- * Automatic Backlight Control metering mode
- * Standard autoexposure program (with automatic shift as you zoom the lens)
- * Single-Shot (one-frame-at-a-time) film advance

2. ZOOMING THE LENS

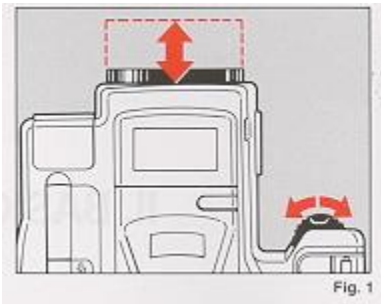

The Mirai's built-in 35 - 135mm Zoom Lens lets you get closer to your subject without changing your position. This lets you easily select the composition that best suits your subject.

To zoom the lens, just rotate the Zoom Selector Dial (Fig. 1) until your subject is framed properly. The nominal focal length you've selected will appear (for about 2 sec.) on the LCD Panel. (Although lens zooming action is continuous, the focal length is displayed on the LCD Panel in 5mm increments 35mm, 40mm, 45mm, etc.)

3. AUTO FOCUSING

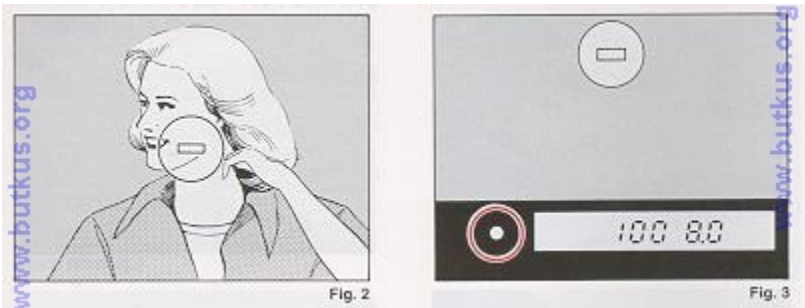

1. Set the subject you wish to take within the Auto focus Frame in the center of the Viewfinder. (Fig. 2)

2. When you press the Shutter Release Button halfway, the green e symbol will light up to indicate the subject in focus. (Fig. 3) With the Sound Switch turned ON, the camera will also beep when correct focusing is obtained.

If the red < and "FLOWER" symbols blink, the auto focusing system is unable to verify correct focus. (See page 38 for suggestions.) If both red < Symbols and the "FLOWER" symbol are blinking, you should move back a little as your camera is too close to your subject. You may also use the Macro Mode. (See page 43.)

* AF (Auto focus) Auxiliary Light:

Infrared light is automatically emitted in the direction of the subject to accurately measure the distance even in dark situations (light emission distance: About 5.5m).

4. SHOOTING

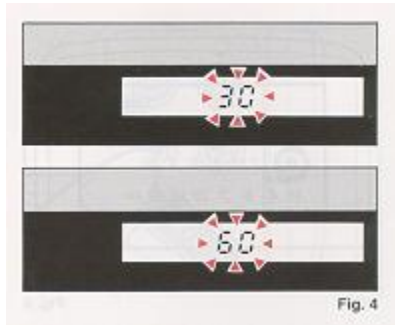

1. Gently press the Shutter Release Button to take the picture. The film advances automatically as soon as the shutter has been released.

In dim lighting conditions, the programmed shutter speed may be too slow for sharp handheld exposures. When this occurs, the shutter speed display in the Viewfinder will blink. (If the lens is set to 35 - 70mm, "L32- 30" will blink; if the lens is set to 70 - 135mm "L32-60" will blink.) (Fig. 4)

We recommend using the built-in flash (see page 65), or a tripod or other sturdy support for the best results in these conditions.

5. REWINDING THE FILM

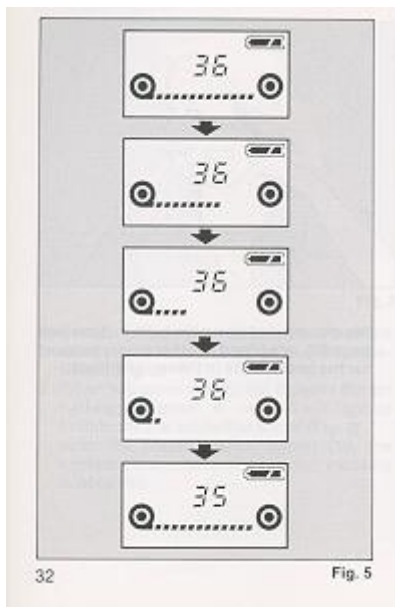

1. The film will rewind automatically when you reach the end of the roll.

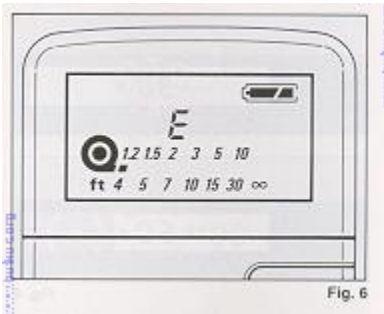

Fig. 6

* Film rewinding is indicated by a series of dashes flashing in sequence from right to left, while the exposure counter is counting down. (Fig. 5)

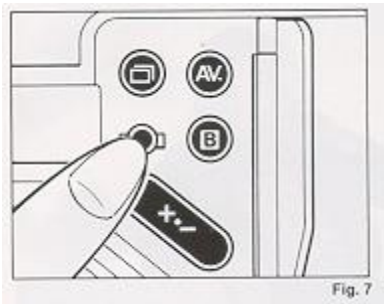

Fig. 7

2. When the film is fully rewound, the motor stops automatically and "E" appears on the LCD Panel. (Fig. 6) Beep sound will also be heard if the Sound Switch is set to the "speaker sound" position. You may now open the Back Cover to unload the film.

* The shutter release is locked when "E" is displayed. However, power zooming and auto focus functions will remain operative, and flash (if in up position) will charge.

3. If you wish to rewind the film before the end of roll is reached, push the Recessed Manual Rewind Button under the Creative Control Panel Cover with your fingernail or a pen, for about 2 seconds. (Fig. n

* Even if the Non-DX Film is used, your camera will usually rewind the film when the end of the roll is reached. If it does not, you will have to rewind the film manually by pressing the Manual Rewind Button located under the Creative Control Panel Cover. (See page 33.) Upon completion of rewinding, the film leader is normally pulled completely inside the cassette. If you wish to leave some leader outside the cassette (for reloading, etc.) push the Manual Rewind Button once while the film is rewinding.

III. MAKING THE MOST OF YOUR CAMERA

III. MAKING THE MOST OF YOUR CAMERA ...37

1. Auto focus Techniques ...38

2. Pre-Focus Shooting ...40

3. Manual (Power) Focus ...42

4. Macro Setting ...43

5. Continuous Shooting Mode ...46

6. Metering Modes ...49

7. Understanding Programmed AE ...53

8. Auto Program Shift ...53

9. Manual Program Shift ...54

10. AE Lock ...56

11. Exposure Compensation ...58

1. AUTO FOCUS TECHNIQUES



Your camera is equipped with a highly accurate auto focus system that is designed to operate efficiently under most shooting conditions. However, in certain rare conditions, it will be unable to focus properly.

These conditions include:

Subjects with poor contrast, such as misty scenes or uniformly white or black objects.

(Fig. 1)

Subjects with an obstruction in front of them, such as caged animals at the zoo, subjects shot through leaves, etc. (Fig. 2)

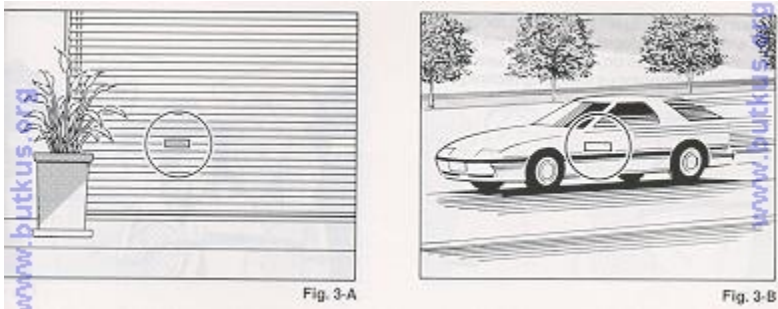

Subjects with repeating patterns or those containing only horizontal lines. (Fig. 3-A)

Subjects moving fast (Fig. 3-B)

Subjects that are extremely bright in the center of the screen

* Please be aware that some special filters cannot be used with this camera.---

When AF is impossible, the red < Symbols will flash in the Viewfinder. If this occurs, you must use either pre-focus or switch to the manual focus mode.

2. PRE FOCUS SHOOTING

When the main subject you wish to focus on is not within the Autofocus Frame, or if the subject is difficult to focus on, you should use one of the following pre-focus shooting techniques.

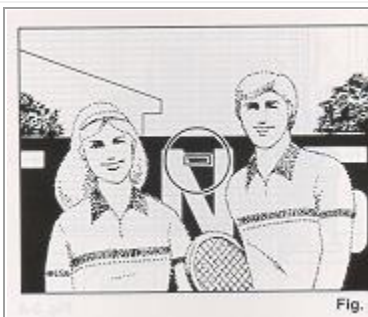

· When the subject is not within the Autofocus Frame:

1. If you want to photograph two or more people, there may be cases where the subject are not within the central Autofocus Frame. If you release the shutter under such conditions, the people (the main subject) will be out-of-focus. (Fig. 4)

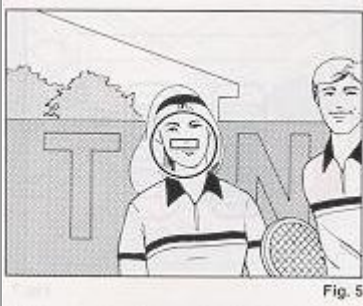

2. Move your camera so one of the people appears in the Autofocus Frame. Gently press the Shutter Release Button halfway so that the green O symbol lights up in the Viewfinder and the correct focus distance is indicated on the LCD Panel. Keep holding your finger halfway down on the Shutter Release Button. (Fig. 5)

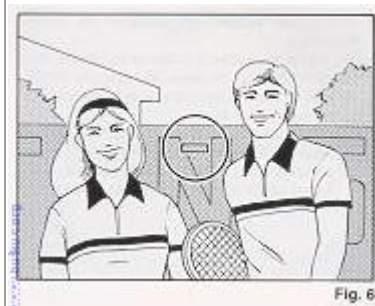

3. Now return your camera to its original position so that all the subjects are properly composed in the frame again, and depress the Shutter Release Button fully to take the picture. (Fig. 6)

3. MANUAL (POWER) FOCUS

· When the subject is difficult to auto focus on:

1. Find another subject at about the same distance from your camera. You can pre-focus on that subject in the same way as described in the page 40-41.

* When you remove your finger from the Shutter Release Button, the pre-focused condition is cleared, so that you can prefocus again as many times as you wish.---

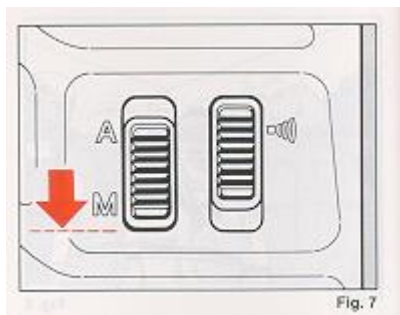

1. Set the Focus Mode Switch to M (Manual). (Fig. 7)
2. Center the Focus Frame on your subject.

3. Rotate the dual-purpose Zoom Selector Dial while keeping the ME (Manual Focus) Button depressed until the subject appears sharp and the green focus signal lights in the Viewfinder. (Fig. 8)

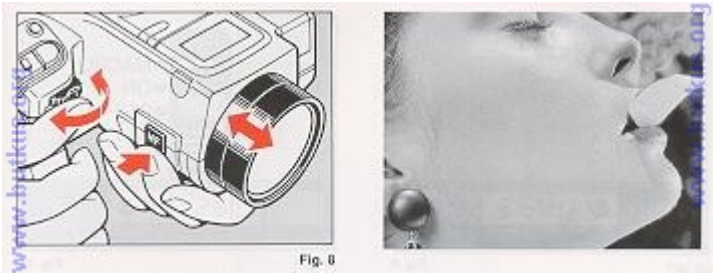

4. Gently press the Shutter Release Button to take pictures.

* This chart illustrates the focus signals when the Focus Mode is set to M.

• :Your subject is in focus.

:Rotate the Selector Dial in the direction of arrow (toward near).

< :Rotate the Selector Dial in the direction of arrow (toward infinity).

4. MACRO SETTING

Close-up photography is possible at distances between 1.2m (3.9ft.) and 0.49m (1.6ft). See above photograph.

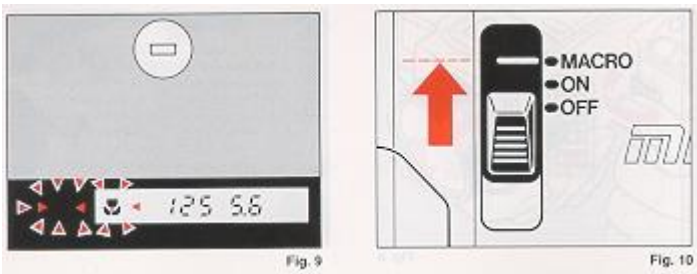

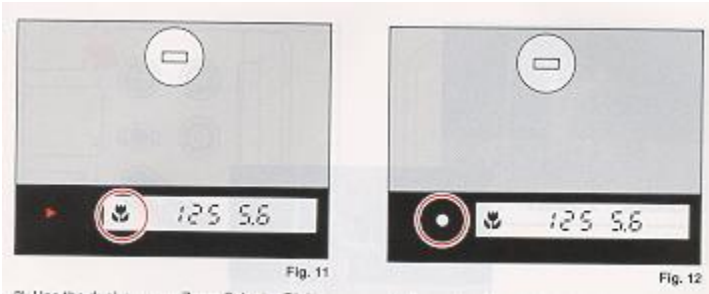



Fig. 9

If the  and/or < blinks when you press the Shutter Release Button halfway, your camera is too close to your subject. (Fig. 9) You should use the Macro Mode, or move farther away from your subjects. If you choose to use the Macro Mode:

1) Set the Main Operating Switch to Macro. (Fig. 10)



The mark  will light up. (Fig. 11)

2) Use the dual-purpose Zoom Selector Dial to manually focus. The green  symbol lights up to confirm the subject in focus. (Fig. 12)

3) Press the Shutter Release Button fully to take the picture.

* The slow shutter speed warning (blinking shutter speed indicator in Viewfinder) will occur below 1/60 sec.

5. CONTINUOUS SHOOTING MODE

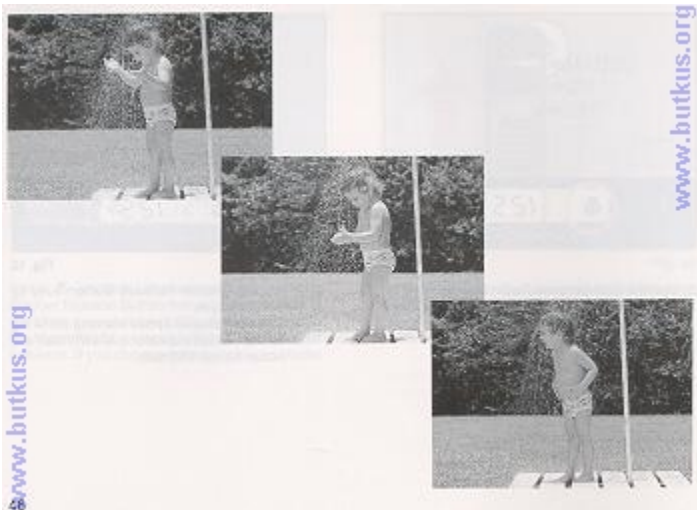

Your camera is designed with 2 types of film advance modes: Single-shot and Continuous. Whenever the camera is turned ON, it is automatically in the single-shot mode.---

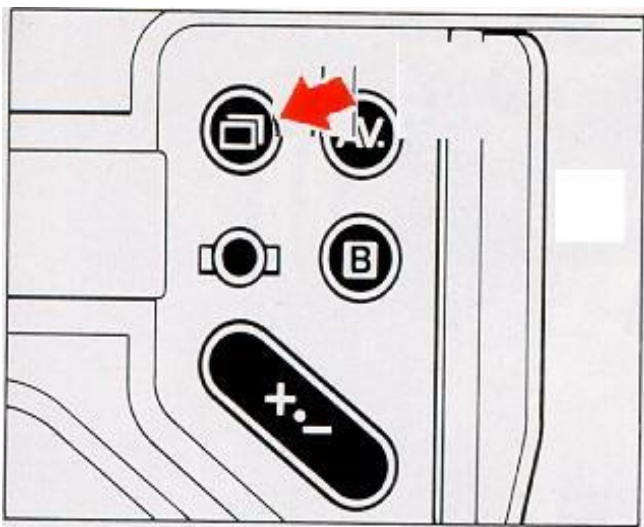

The film advance mode can easily be changed from Single-Shot to Continuous-and back again- by pressing the Continuous Shooting Mode Button, located under the Creative Control Panel Cover. (Fig. 13)

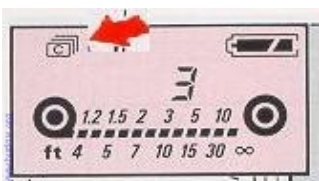

1. Select the Continuous Shooting Mode by depressing the Continuous Shooting Mode Button. Confirm that the mark appears on the LCD Panel. (Fig. 14)

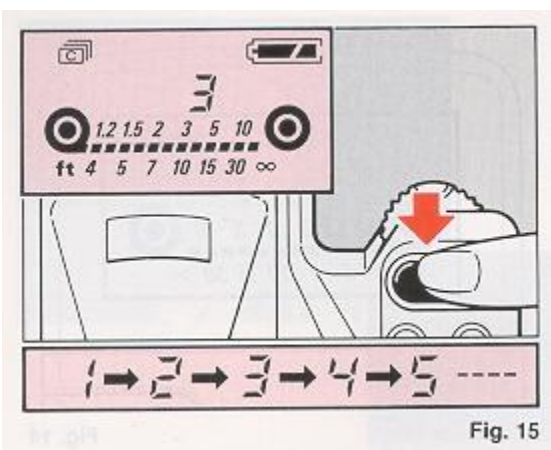

Fig. 15

2. Press and hold down the Shutter Release Button. Your camera will continuously take pictures at a rate of two frames per second as long as Shutter Release Button is held down. (Fig. 15)

* To return to the Single-shot Mode, press the Continuous Shooting Mode Button again or the Reset Button.

* Do not use the built-in flash in the Continuous Mode. The flash will not recycle fast enough to keep up with the continuous shooting rate. (If the flash is used in the Continuous Mode, the shutter release will "lock-up" until the flash has recycled then it will fire automatically.)

6. METERING MODES

Your camera is designed with 2 types of exposure metering systems: Automatic Backlight Control (ABLC) and Center-weighted Average. Either system can be selected by pressing the AV Button. Which one you choose depends on your subject and experience. Whenever the camera is turned ON, it is automatically in the ABLC Mode.



Automatic Backlight Control (ABLC) (Fig. 16)

The ABLC setting is effective when your subject is surrounded by an especially light or dark background. This modifies (increases or decreases) the average reading to obtain proper exposure for the main subject.---



Center weighted Average Exposure Metering System (Fig. 17)

It is ideally suited to silhouette photography and similar techniques since it provides the average metering between the subject and the background lighting. Center-weighted Average Metering Mode is also recommended when using reversal film.

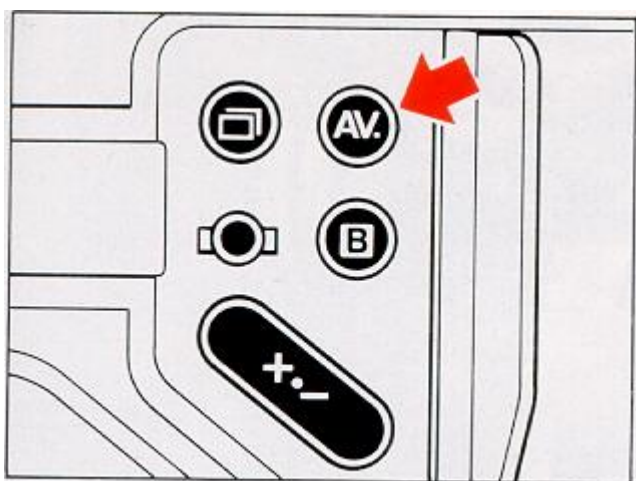

Fig. 18

To select Center weighted Averaging:

1) Press the AV (Average) Button under the Creative Control Panel Cover. (Fig. 18)

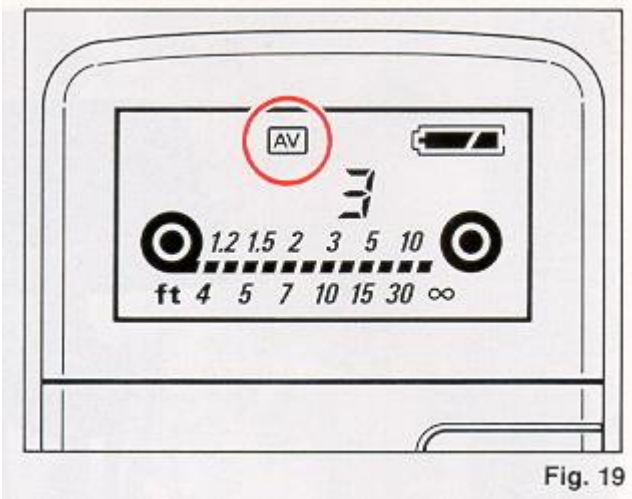

Fig. 19

2) Make sure that the AV mark appears on the LCD Display Panel. (Fig. 19)

* To cancel the Center-weighted Average and return to ABLC, press the AV Button or the Reset Button.

7. UNDERSTANDING PROGRAMMED AE

The Mirai automatically sets the proper speed and aperture combination according to the rightness of your subject. This allows you to imply point and shoot, concentrating on composition and capturing the moment.

8. AUTO PROGRAM SHIFT

Your camera is designed with four different auto exposure programs. The program modes are set automatically according to the lens focal length (wide, standard, tele, or macro mode) of the built-in zoom lens to ensure correct obtaining the correct exposure. For detailed specifics on each program, see page 86.

9. MANUAL PROGRAM SHIFT



When you wish to take pictures with a increased depth-of-field requirement, such as scenics and portraits, or to capture action with a faster shutter speed, you can easily modify the preset programs according to the taking conditions and the subject. For detailed specifics on the program, see pages 87 - 90.



To use Manual Program Shift:

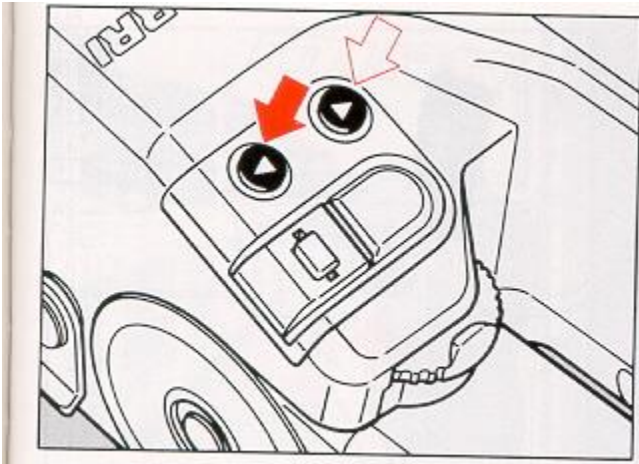

Fig. 20

1) Press the Up/Down Buttons to select the desired shutter speed and aperture combination according to your subject and brightness level. (Fig. 20)



Fig. 21

2) Monitor your selection in the Viewfinder display. (Fig. 21) The Viewfinder LCD will display an S symbol and the shifted shutter speed/aperture combination.

3) To cancel Manual Program Shift, press the Reset Button or turn the Main Operating Switch to OFF.---

10. AE LOCK



Example 1

When the contrast between a subject and background is excessive (such as a backlit or spot-lit scene), under or over exposed pictures may result. Use the AE lock to remember, or lock into the camera's electronic memory, a pre-selected close-up reading of the subject.

Example 1: Not using the AE lock

Example 2: Using the AE lock. Fig. 22

1. Bring the camera close enough to subject so the exposure will not be affected by the back ground.

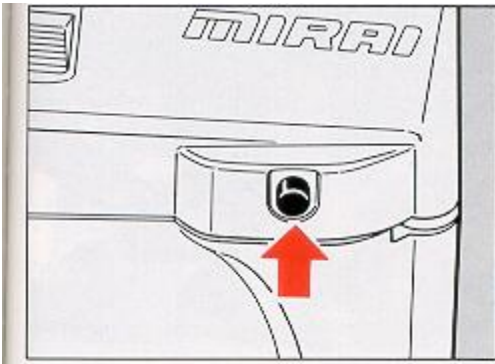

Fig. 22

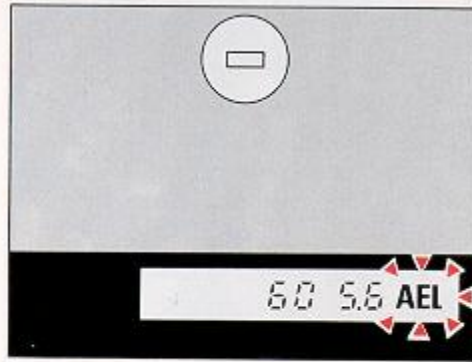

Fig. 23

2. Press the AE Lock Button once to memorize the exposure. (Fig. 22)
A flickering AEL is now displayed on the Viewfinder LCD. (Fig. 23)

3. The AE Lock is automatically cancelled after the Shutter is released.

* To cancel the AE Lock before taking any pictures, press the AE Lock Button again or press the Reset Button.

* When the power source goes to OFF condition automatically to save power, AE Lock is cancelled.

11. EXPOSURE COMPENSATION



If the contrast is excessive between your subject and the background, you can use the Exposure Compensation with the Center-weighted Average Exposure Metering System.

Exposure Compensation may also be used to intentionally take over/underexposed pictures for creative effects, and to adjust ISO speeds away from DX values or set Non-DX films to ISO speeds other than the default value of ISO 100.



Exposure adjustment examples:

SUBJECT	EXPOSURE ADJUSTMENT
Figures against backlight scenery with much sky	+4 to +1
Figures with snow covered mountains or the	+1

sea on the background	
Spotlit figures (on stage, etc.)	-1 to-4

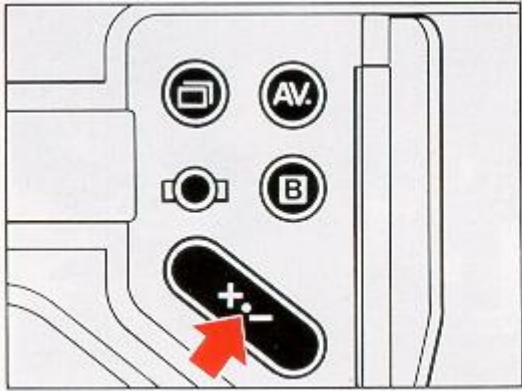

Fig. 24

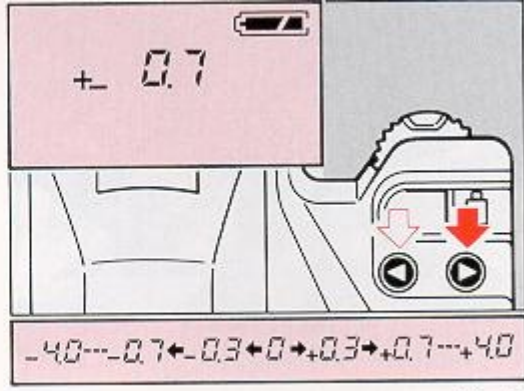

Fig. 25

1. Set the Center-weighted Average Metering Mode.
2. Press and hold the Exposure Compensation Button. (Fig. 24)
3. Press the Up or Down Button (Fig. 25) until the desired amount and direction of compensation appears on the top LCD Display and the new aperture and shutter speed combination appears in the Viewfinder. Adjustment will be made up to +4 EV (stops) in 1/3 EV increments.---

Non-DX ISO Adjustment

Non-DX films default to a nominal ISO 100. If you are using ISO 200 film, set Exposure Compensation to -1.0 to reduce exposure by one step. Similarly, if you are using a Non-DX Film rated at ISO 25, set the Exposure Compensation to +2.0.

12. BULB (LONG EXPOSURE) PHOTOGRAPHY

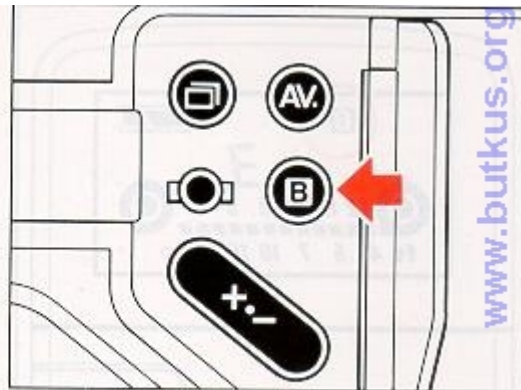

Fig. 26

The B (Bulb) setting is used for shooting night scenes or making long exposures of other subjects.

1. Set the Bulb Mode by pressing the B (Bulb) Button under the Creative Control Panel Cover. (Fig. 26)---

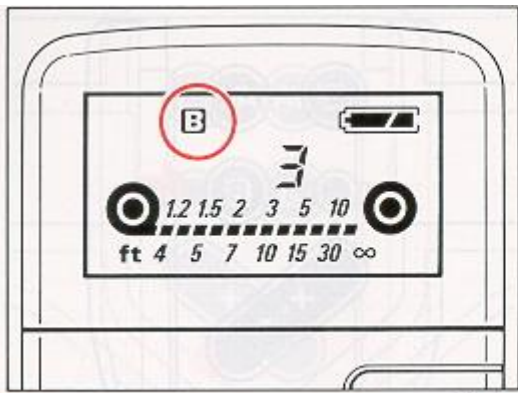

Fig. 27

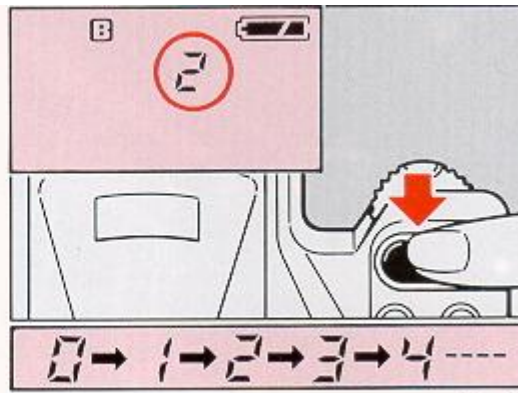

Fig. 28

2. The B mark will appear in the LCD Panel. (Fig. 27)

3. When the Shutter Release Button is pressed, the shutter will be kept open as long as the button remains depressed. Fig. 28

* A digital count up of the exposure time will be shown on the LCD Display Panel as long as the Shutter Release Button is held down. (Fig. 28)

* To cancel the Bulb Mode, press the B (bulb) Button again, or press the Reset Button.

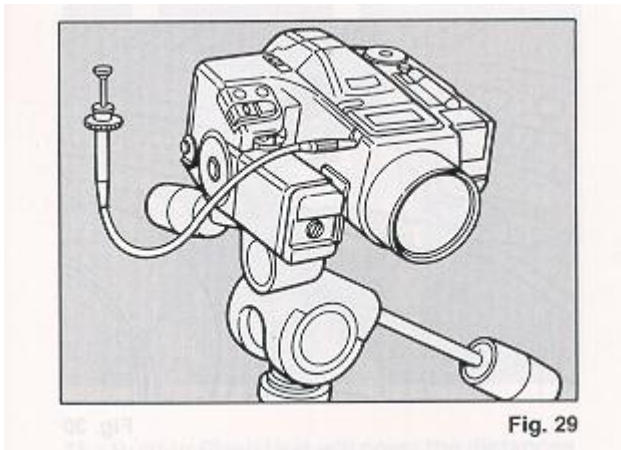

Fig. 29

* Use a tripod and Ricoh Electric Cable Release for bulb photography to prevent the unintentional movement of your camera. (Fig. 29) (Before you plug the electric cable release into your camera, turn the Main Operating Switch to OFF)

13. REMOTE CONTROL SOCKET

Your camera is equipped with an Electronic Remote Control Socket. An Electronic Cable Release with a 50cm (1.5ft.) cord and a companion 10-meter (soft.) extension cord are available from Ricoh as options for use in remote control photography. Various other methods of remote control can be used by plugging an infrared sensor, audio sensor, remote controller; etc. into this socket. Such devices allow you to capture the natural expressions of subjects from a distance.---

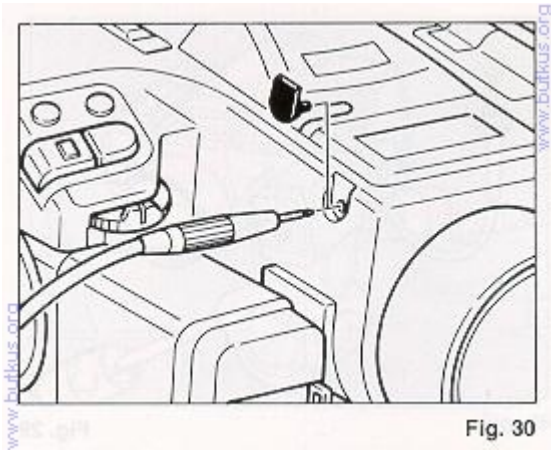

Fig. 30

1. Turn the Main Operating Switch OFF before connecting or disconnecting any cords or controllers. (Fig. 30)
2. Plug the remote controller into the Remote Control Socket of your camera.
3. Turn the Main Operating Switch ON. Position your camera for the best composition.
4. Aim at your subject and take a picture.

14. FLASH PHOTOGRAPHY

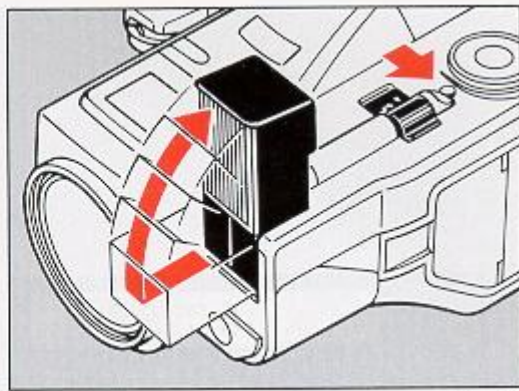

Fig. 31

The Built-in Flash Unit will cover the distances to about 4.0m (13.1 ft.) at telephoto position to approx. 5.0m (16.4ft.) at wide-angle position (negative film ISO 100), thus making it ideal for use with the nominal, wide-angle and telephoto position of the built-in 35-135mm zoom lens. This makes possible a world of special applications as well as the ultimate in point-and-shoot simplicity.

1. Under dim light conditions, the shutter speed will blink if the light is insufficient when the Shutter Release Button is depressed halfway. Slide the Flash Power. Fig. 31

Switch toward the outside of the camera. (Fig.31) The flash unit will pop up and begin charging. Before charging is complete, the Flash Ready indicator "LIGHTING BOLT" in the Viewfinder will blink. (Fig. 32)

2. When fully charged, the Flash Ready Indicator "LIGHTING BOLT" will light steadily in the Viewfinder. Flash charging typically takes about 3.5 sec.

* When the Shutter Release Button is depressed, the mark "LIGHTING BOLT" will blink rapidly if your subject is too far away for a correct exposure. Move closer to your subject and/or zoom to a shorter (wide-angle) focal length.



Fig. 32

3. Focus on your subject and press the Shutter Release Button to take your picture automatically.

* Do not use the flash in combination with the Continuous Shooting Mode because the flash will be unable to recycle fast enough to make two exposures per second.

* The shutter speed is set to 1/100 sec. automatically, and the f-stop will be set according to the distance. (This can be observed when the flash is fully charged, by prefocusing on different distances and watching the F-number change in the Viewfinder.)

15. DAYLIGHT FILL-IN FLASH



When taking pictures in strong backlighting, the result will invariably be an underexposed (dark) subject. There are several ways to ensure a proper exposure of a backlit subject, including using the Automatic Backlight Control metering mode or manually adjusting the exposure using the AE Lock (see page 56), the Exposure Compensation Mode (see page 58). You can also use the Daylight Fill-In Flash Mode.

* When the Fill-in Flash Button is pressed for flash photography in a dark area, the shutter speed will automatically slow down to allow more light from the background to enter the camera, thereby more evenly balancing subject and background illumination. Use a tripod to prevent the unintentional movement of your camera.

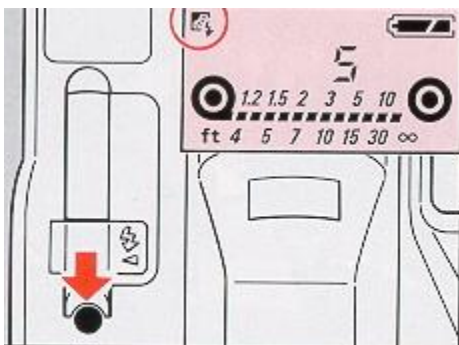

Fig. 33

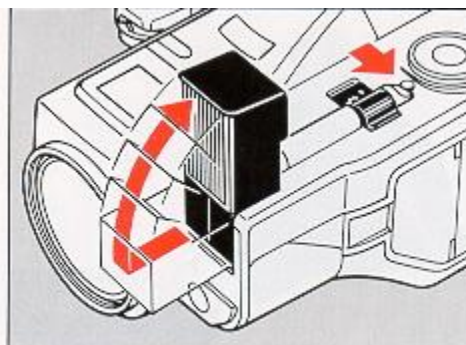

Fig. 34

To activate Fill-In Flash:

1. Press the Fill-in Flash Button to set the Fill-in Flash Mode. Confirm that the "SUN" mark is shown on the LCD Panel. (Fig. 33)
2. Pop up the flash unit. (Fig. 34)
3. When fully charged, the Flash Ready Indicator "LIGHTING BOLT" lights up inside the Viewfinder. When charging, the Flash Ready Indicator blinks.
4. Focus on your subject and press the Shutter Release Button to take your picture.

* When the Shutter Release Button is depressed, the Flash Ready Indicator "LIGHTING BOLT" will blink rapidly if your subject is too far away for a correct exposure. Move closer to your subject and/or zoom to a shorter (wider angle) focal length.---

16. FLASH PHOTOGRAPHY WITH SPEED LIGHT SL-310M

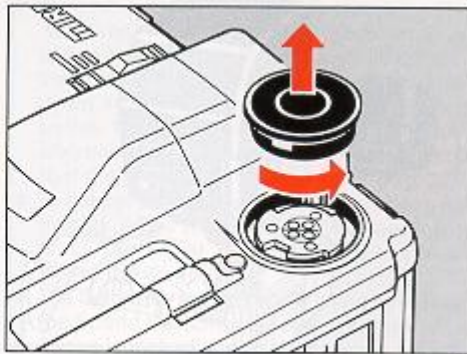

Fig. 35

With the optional Speedlite SL-301M, direct, through-the-lens, flash control is possible for total distance and creative depth-of-field control.

1. Turn the Hot Shoe Cover counterclockwise and remove it from the camera. (Fig. 35)

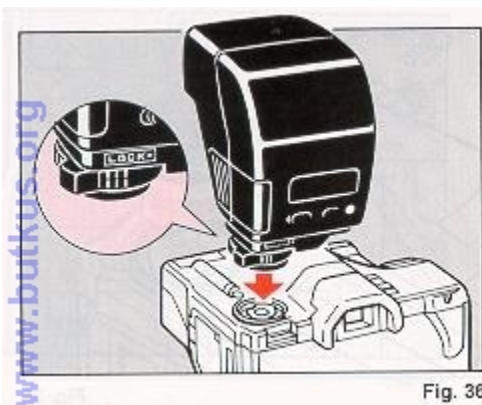

Fig. 36

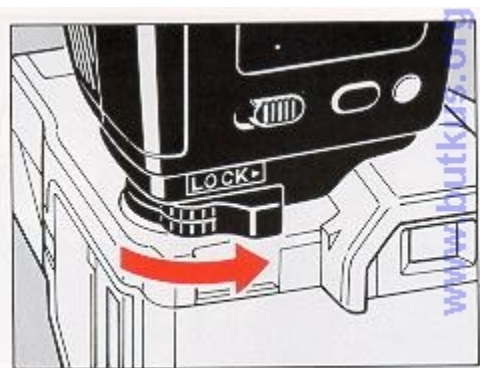
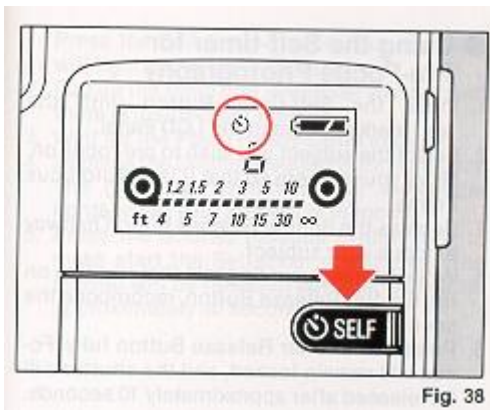

Fig. 37

2. Insert the flash unit into the Hot Shoe and turn the lock lever counterclockwise in the direction of arrow until it fastens. (Figs. 36, 37)
3. Turn the Flash Power Switch ON, as well as the Camera Main Operating Switch.
4. After the Flash Ready Indicator lights in the Viewfinder and/or on the back of the flash unit, take the picture.

* If the Flash Ready Indicator S blinks rapidly when the Shutter Release Button is depressed halfway, your subject is too far away for a proper exposure. Move closer to your subject and take the flash photograph by following steps shown previously.---

17. USING THE SELF-TIMER



The Self-timer is used to include yourself in your pictures. When activated, the Self-timer provides a delay of approximately 10 seconds.

1. Press the Self-timer Button. The Hi) mark will light up on the LCD Panel. (Fig. 38)
2. Depress the Shutter Release Button halfway The green • symbol in the Viewfinder lights when your subject is in focus.
3. Press the Shutter Release Button fully. The Self-timer Indicator LED in the front panel will blink and the self-timer audible beep (if switched ON) will beep during the countdown and remain on for the last 2 seconds before the shutter releases. The lamp will also blink and then light steadily to warn you that the shutter will release soon. (Fig. 39)

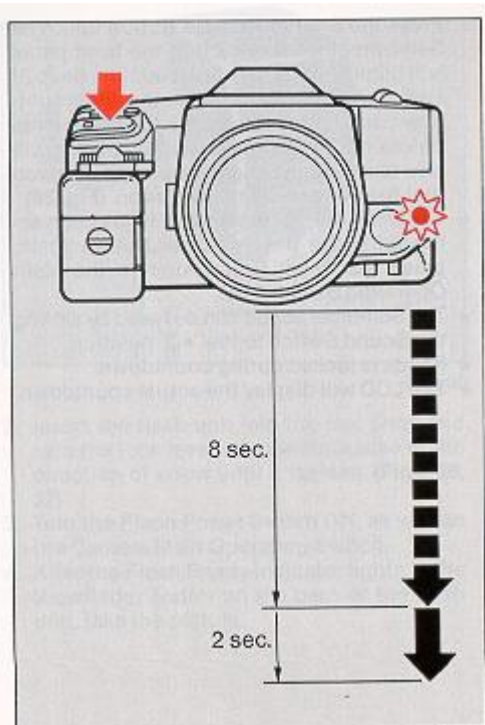

72

* To cancel the Self-timer after it has been activated, press the Self-timer Button again, press the Reset Button or turn the Main Operating Switch OFF.

- * The Self-timer sound can be heard by setting the Sound Switch to the A) position.
- * Focus is locked during countdown.
- * The LCD will display the actual countdown.

* Using the Self-timer for Pre Focus Photography

1. Press the Self timer Button until the "SELF TIME" mark appears in the LCD Panel.
2. Select the subject you wish to pre-focus on. Move your camera so that it is in Auto focus Frame.
3. Depress the Shutter Release Button halfway to focus your subject.
4. While keeping your finger in that position on the Shutter Release Button, recompose the scene.
5. Press the Shutter Release Button fully. Focus will remain locked, and the shutter will be released after approximately 10 seconds.

18. USING THE SELF-TIMER WITH FLASH

1. Press the Self-timer Button. The () mark will light up on the LCD Panel.
2. Pop up the flash unit whenever you suspect there is insufficient light.
3. Wait for the Flash Ready Lamp to Light.
4. Depress the Shutter Release Button halfway. The green e symbol in the Viewfinder lights when your subject is in focus.
5. Press the Shutter Release Button fully to make start the Self-timer countdown. The shutter will be released automatically after approximately 10 seconds.

19. RESET BUTTON

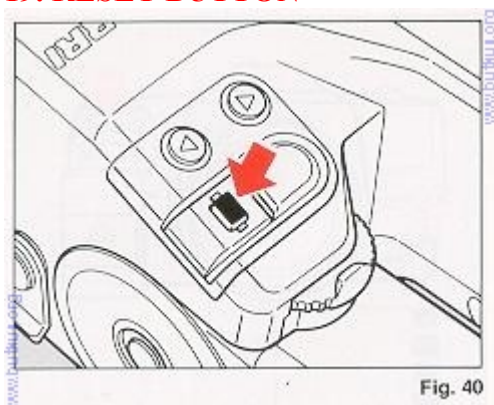

This button is used to revert all modes to their default settings. First, if necessary, lightly press the Shutter Release Button to reactivate the system and see the currently entered information in the LCD Panel.

Next, press the Reset Button to return all of the following items to their default values. (Fig. 40)

- Exposure compensation to +0 from any manually entered value (0 to +4 EV).
- Film advance mode to single - if presently set for Continuous Shooting.

- Exposure metering system to Automatic Backlight Control if presently set for Center weighted Average.
- Daylight flash mode cancelled. After shooting a daylight fill-flash picture, press the Reset Button and return the flash unit to the flash off position.
- Manually-set Program Shift is cancelled, and camera is set to the standard automatic program.
- Self-timer will be cancelled if it has been set or started.
- AE Lock is cancelled before taking any pictures.
- Bulb (B) setting is cancelled if it has been set.

IV. CARING FOR YOUR CAMERA

1. Do not touch lens or shutter surfaces with your fingers to clean them. Gently blow dust away with a blower or wipe gently with soft cloth. If you must clean the lens surface use only one drop of lens cleaning fluid on a rolled-up camera lens tissue.
2. Avoid excessive shock, humidity or salt, as these conditions may make your camera malfunction. When you use the camera at the beach, in a corrosive atmosphere, or in a place where chemicals are used, carefully wipe it clean.
3. Do not expose your camera, film and batteries to temperature extremes.
4. Do not leave your camera in a car at the beach, in the desert, or in other high temperature conditions to avoid possible damage.
5. When using a tripod, do not try to force a long screw into the socket. (The screw length should not extend more than 5.7mm (1/4~))
6. Do not store the camera near a television, radio or other strong magnetic source....
7. Store camera in a low humidity and dust and vibration-free place.
8. When not shooting, switch off the power.
9. Do not allow the battery contacts, strobe contacts, or date back contacts to get dirty.
10. Do not touch nor allow foreign objects to get caught in any fast moving parts, especially the shutter.
11. Do not have this camera disassembled or lubricated anywhere but an authorized service center.
12. Only use filters designed for this camera. (Oversized filters, lens shades, etc. may interfere with automatic lens movements and permanently damage internal parts.)

V. HELP (Troubleshooting guide)

Commonly asked Questions and Answers about your New Camera...

Q. No camera functions are working. What should I do?

1. Make sure the Main Operating Switch is set to ON.
2. Check to see that a battery is loaded and/or inserted correctly

Q. Why won't the shutter fire when I press the Shutter Release Button?

1. Check the Viewfinder. If the <, "LIGHTING BOLT" or "FLOWER" symbols are blinking, the camera cannot auto focus properly on your subject. You should either focus on a more distinct, detailed subject or switch to Macro (see page 43) or Manual Focus (see page 42).
2. The flash may still be charging. Wait a few seconds until the flash is fully charged.
3. A rewound roll of film may still be in the camera. Remove the roll and replace it with a fresh one.
4. The auto load is not properly done. Load the film again into camera.

Q. The camera is on but the lens won't zoom. What should I do?

1. Make sure the Main Operating Switch is at the ON position (not MACRO).
2. If you're using flash, wait until the flash is fully recharged.
3. The lens will also not zoom while the film is being advanced or rewound or if the self timer is operating (the Self-timer Indicator LED is lit and blinking).

Q. Why won't the lens auto focus properly?

1. The auto focus system may not operate with very bright or overall dark/light subjects (lack of contrast) or with subjects that are very close to the camera. With a very bright or overall light/dark subjects, try prefocusing on another object at about the same distance from the camera or switch to Manual Focus (see page 42). With too-close subjects, move further away from the subject or use the Macro Mode (see page 43).

Q. The flash doesn't fire. What should I do?

1. Make sure the flash is popped up.
2. In bright lighting conditions, press the Fill in Flash Button.
3. Wait until other camera functions (e.g.: zooming and film advance/rewind) have been completed.

Q. I just loaded a new roll of film. Why isn't it advancing?

1. The film probably didn't load properly. Open the camera back and make sure to pull the film leader to the film leader mark (see page 13).

Q. After pressing the Self-timer Button, the timer won't activate. Why?

1. After pressing Self-timer Button, you must lightly press the Shutter Release Button, obtain the green focus OK confirmation in the Viewfinder, and fully depress the shutter release to activate the self-timer. (See page 71)
2. You may be in the Bulb Mode. To return to Programmed AK, press the Reset Button or turn the camera off and on again before activating the self-timer.

Q. I've reached the last frame on my mm roll but the film won't rewind. Why?

1. With DX-encoded film, you'll frequently get one or two "extra frames (e.g.: 26 on a 24-exposure roll).
2. If you're using non-DX-encoded film, the camera may not rewind it automatically. Press the Manual Rewind Button under the Creative Control Panel to rewind the film.

Q. Why is there no display in the LCD Panel or Viewfinder?

1. To conserve battery life, the camera automatically shuts off the display after about 16 seconds. Press the Shutter Release Button lightly to activate the display and all other operating functions.

Q. I'm trying to take a picture but shutter speed display is blinking in the Viewfinder. What does this mean?

A. Your camera is warning you that the ambient light is too low for steady hand-held shooting. When you see a blinking "60" or "30" in the Viewfinder pop up the built-in flash or use a tripod Mother support to steady the camera.

Q. When should I replace the battery?

A. 1. Periodically check the battery symbol in the top LCD Panel. When the  symbol appears, purchase a fresh battery and use it to replace the old one when the camera is not loaded with film. (See pages 11.)
2. When the c symbol appears, replace the battery with new one.

VI. ACCESSORIES



1. DATA BACK DB-5M When the Back Cover of the camera is replaced by the Data Back DB-5M, "Year, Month and Date (3 types)", or "Date, Hour Minute" can be printed on your film.

The automatic dating mechanism is incorporated into the Data Back DB-5M. Once the date is set, no adjustment is necessary until 2019, because leap years and months with 31 or less days are automatically adjusted. When the switch is turned off, it can be used as digital watch.---



2. SPEEDLITE SL -301M The Speedlite SL-301M unit provides Full AE Through-The-Lens f lash and simple daylight flash by measuring light off the film plane and simple pro-fill daylight flash photography.



3. TELE CONVERTER TO 200M Can be easily attached to the lens to obtain magnifications of 200mm (1.5 power).



4. PROTECTION FINER MC UV Can be attached permanently to protect the lens from dirt, dust and shock. It is a multicoated UV Filter that cuts ultra violet rays. For optimum results, it is recommended that the filter be used as often as possible.



5. GRIP BELT GM Increases holding stability when holding camera and thus prevents blurring due to shaking.---

V11. APPENDIX (Charts Diagrams)

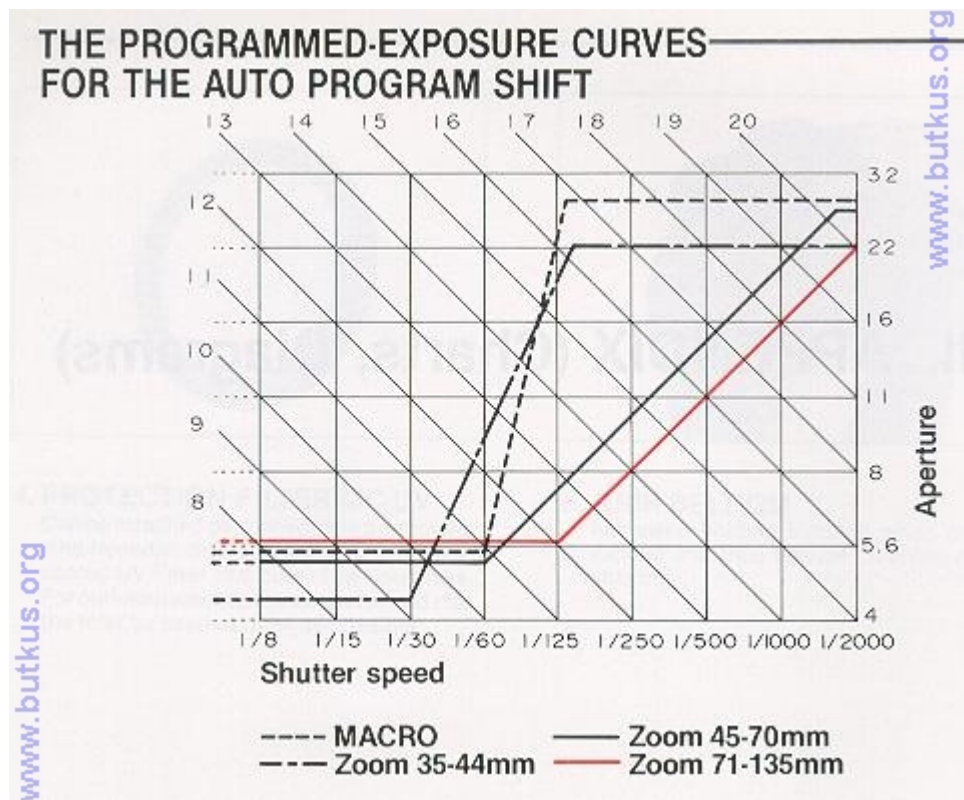

THE PRE-PROGRAMMED EXPOSURE CURVES FOR THE MANUAL PROGRAM SHIFT

MACRO

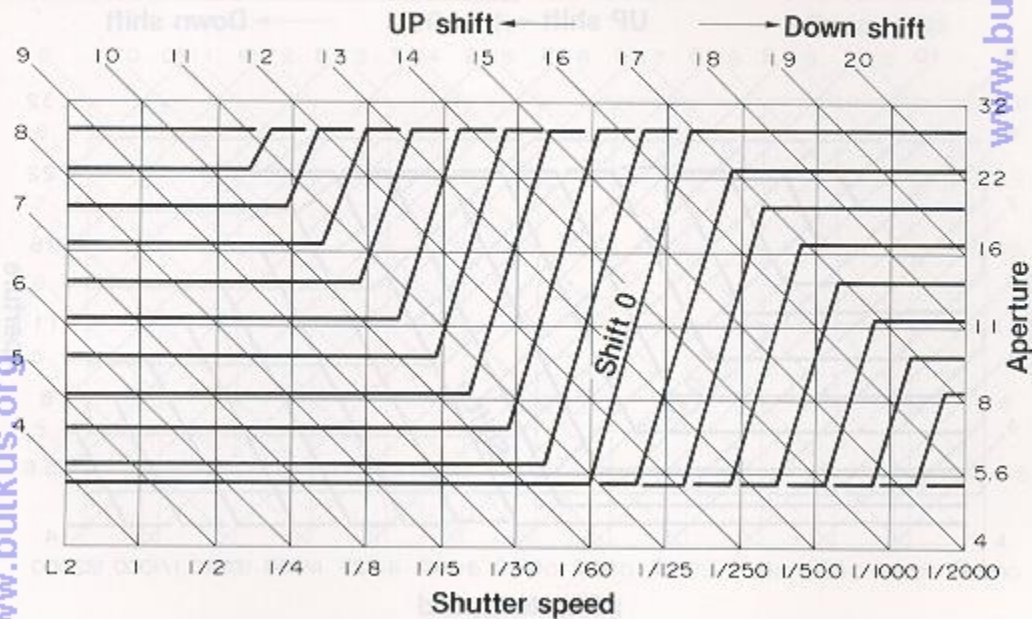

THE PRE-PROGRAMMED EXPOSURE CURVES FOR THE MANUAL PROGRAM SHIFT

FOCAL LENGTH=35-44mm

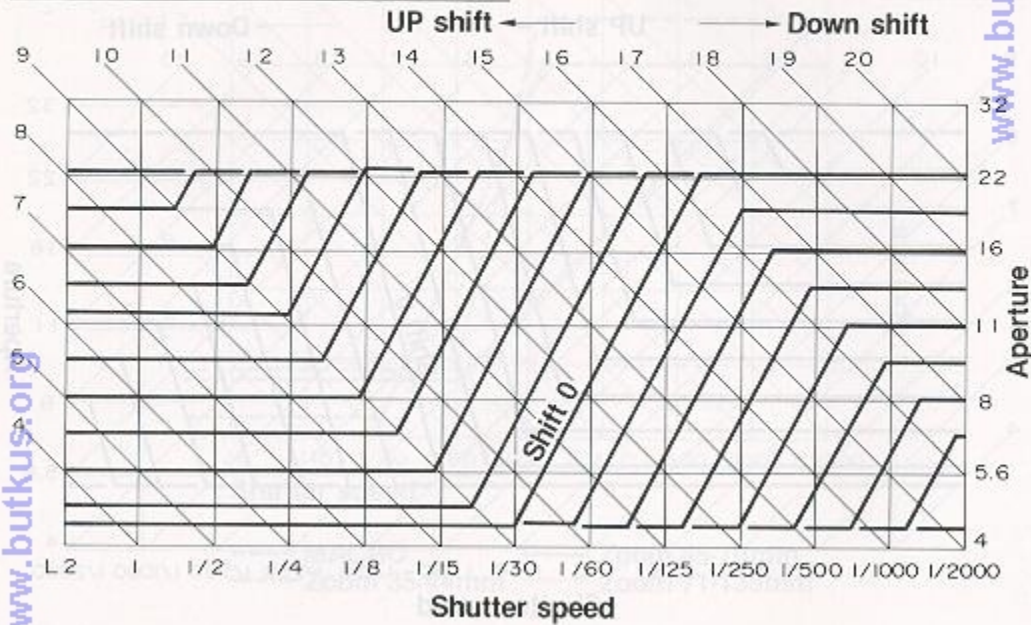

THE PRE-PROGRAMMED EXPOSURE CURVES FOR THE MANUAL PROGRAM SHIFT

FOCAL LENGTH=45-70mm

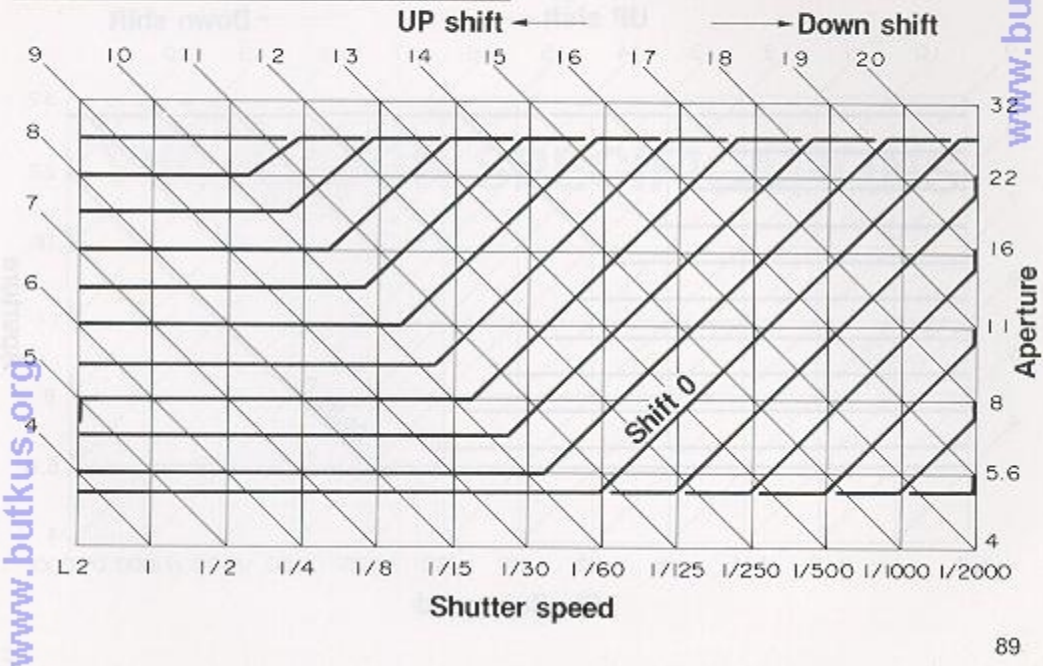

THE PRE-PROGRAMMED EXPOSURE CURVES FOR THE AUTO PROGRAM SHIFT

FOCAL LENGTH=71-135mm

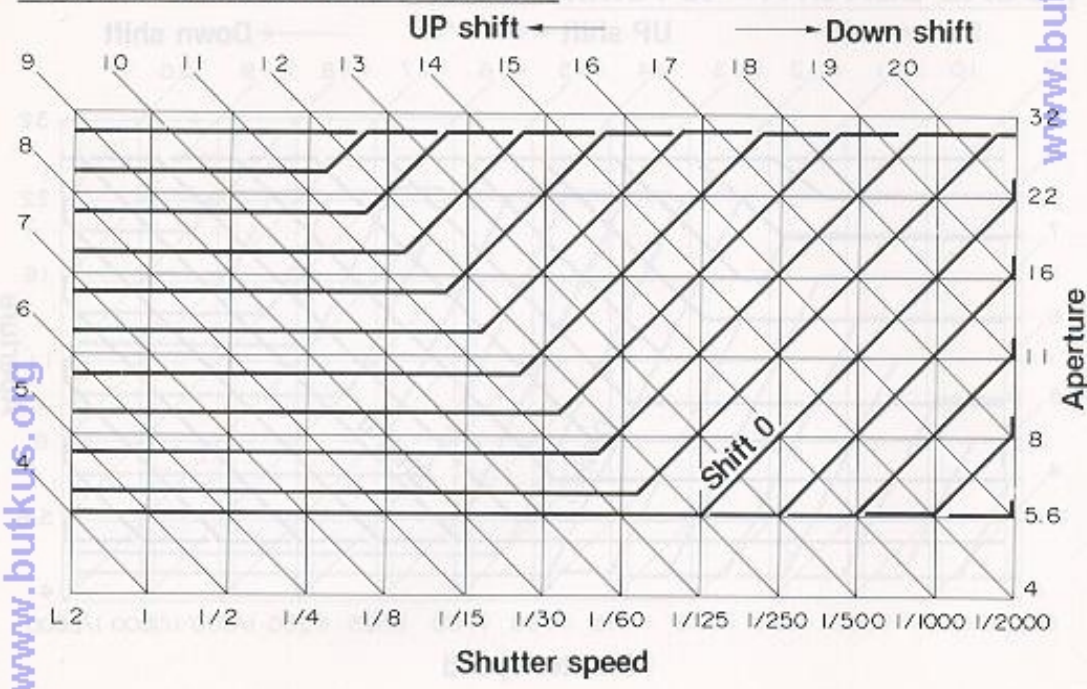

VII. MAJOR SPECIFICATIONS

LENS

Zoom Range: 35mm - 135 mm

Lens Speed: F4.2 - F5.6

Minimum focusing Distance: 1.2m

Macro Distance: 1.2m - 0.49m (by Focus Aid)

Macro Magnification: 1/4.9 (at 0.49m)

Macro Type: Tele Macro

Filter Size: 52mm

Front Lens Diameter: 44mm

Lens Construction: 15 Elements in 13 Groups

Lens Retraction: By 8mm (When Main Switch is Off)

Zooming: Power Zooming

VIEWFINDER

Type: TTL Type

Magnification: x0.80 (at 50mm)

Field of Coverage: 87%

LIGHT MEASUREMENT

Mode: Automatic Back Light Control Mode

Center Weighted Average Mode

AE Lock: Yes

Exposure Compensation: + or - 4EV

EV RANGE: EV4-20

ISO SETTING: 25 - 5000

FOCUSING

Type: TTL Automatic Focusing Single AF Type

AF Distance Coverage: 1.2m - inf.

AF Range: . EV4 - 17 (without Beam Illuminator)

Beam Illuminator: Automatically lights in low light up to about 5.5m

Focus Aid: Possible by Power Focusing
At Macro Mode Use Focus Aid for AF

EXPOSURE

Mode: Program AE with Automatic Shift Capability
(35 - 44mm: Wide, 45 - 70mm: Standard, 71 - 135mm: Tele Program)
Manual Program Shift Possible with Up/Down Button Bulb

STROBE

Type: Flash Matic Type Built-in

Shooting Range: Wide: 1.2 - 5m/Tele: 1.2-4.0m (ISO 100 Negative Film)

Pop-up: Manual Pop-up

Sensor: Yes When Popped-up

Fill Flash: Possible by Fill-Flash Button

Strobe Effective Range: Can be checked before Shooting

Additional Strobe: Can be attached (G. NO. 30)

Synchro Speed: 1/100 sec.

SHUTTER

Type: Focal Plane Type

Speed: 32 sec. - 1/2000 sec. and Bulb

VIEWFINDER

Screen Information: Matt Only (Not Interchangeable) with AF Frame

In Focus, Too Far, Too Close, Strobe Charge (by LEDs) F-Stop
Shutter Speed (pulsates as slow shutter warning), Exposure
Over, Under, AE Lock, Macro, Exposure Compensation

OUTSIDE LCD PANEL Focusing Distance, Focal Length,
Film Loaded, Film Set, Continuous Winding, Average
Metering, Self Timer, Fill Flash, Exposure Counter Battery Condition

CONTROL BUTTONS

COVERED: Exposure Compensation, Manual Rewind, ABLC/Average,
Bulb/Auto Exposure, Single/Continuous Winding

OTHERS

Remote Control Socket: Yes

Databack: Can Be Attached

Selftimer: 10 Seconds

Battery: Lithium (CR-P2), or AAx4

Size: 135mm (W)x126mm (D)x81mm (H)

Weight: 1010g

(SPECIFICATIONS ARE SUBJECT TO CHANGE WITHOUT NOTICE)